

- SBG-03, SBG-06, SBG-10 引導動作型溢流閥，具有極低噪音之特性。
- Pilot operated relief valve SBG-03, SBG-06, SBG-10 is designed with low noise.

SBG-03.06.10

型號意義 How to order :

S B G - 06 - ※ R
 1 2 3 4 5 6

1	低噪音型	Low noise
2	系列號	Series
3	板式連接	SUB-Plate mounting
4	口徑代號	Valve size 03:3/8", 04:3/4", 10:1-1/4"
5	壓力調整範圍	Pressure adjusting range
6	壓力把手位置	Pressure Handle position
	R: 把手朝壓力口方向 (標準品・無記號)	R: Handle is facing to the pressure port (standard, no remarked)
	L: 把手朝回油口方向	L: Handle is facing to the tank port

產品規格 Specification :

名稱 Name	口徑 Valve Size	型號 Model	壓力調整範圍 Pressure Adj. Range (Kgf/cm ²)	最大流量 Max. Flow (ℓ/min)	重量 Weight (Kg)
引導動作型溢流閥低噪音型 Low Noise Type Solenoid Controlled Relief Valves	3/8	SBG-03	B: 7~70	100	5
	3/4	SBG-06	C: 35~140	200	6.2
	1-1/4	SBG-10	H: 70~225 2H: 140~315	400	9.5

附件 Attachment :

型號 Model	安裝螺絲 Mounting bolts	O 型環 O-Ring
SBG-03	M12 x 40L 4 支 piece	JIS B 2401-1B-P9 1 條 piece JIS B 2401-1B-P20 2 條 piece
SBG-06	M16 x 45L 4 支 piece	JIS B 2401-1B-P10A 1 條 piece JIS B 2401-1B-P28 2 條 piece
SBG-06	M20 x 60L 4 支 piece	JIS B 2401-1B-P10A 1 條 piece JIS B 2401-1B-P36 2 條 piece

圖形符號 Graphic symbol :

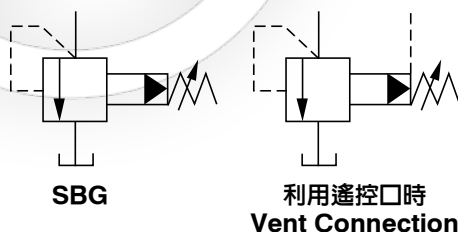

SBG-03.06.10

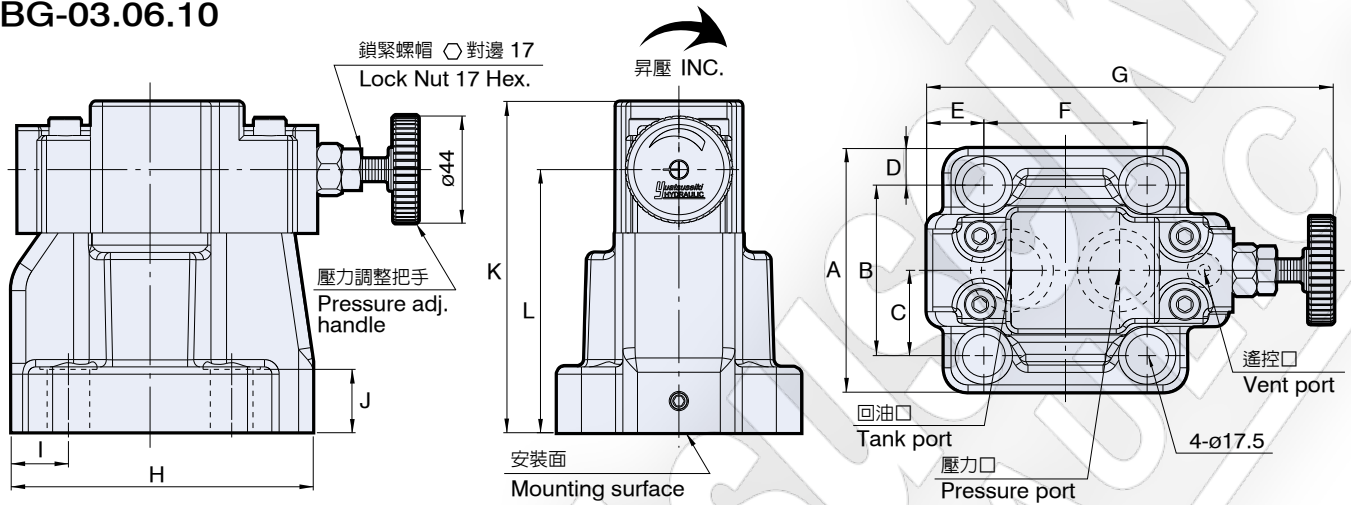

單位 Unit : mm

型號 Model	A	B	C	D	E	F	G	H	I	J	K	L
SBG-03	78	54	27	12	34.5	53.8	166	107	26.5	23	134	106
SBG-06	100	70	35	15	23.5	66.7	168.5	124	23.5	26	136	108
SBG-10	127	82.6	41.3	22.2	20.5	89	187	155	20.5	36	145	120

性能曲線圖 Performance curves

測定位置：閥前方1m處 Measuring position: At 1m back from the valve front

■ 噪音特性 Noise

使用油：黏度 Test fluid viscosity: 35mm²/s {cSt}

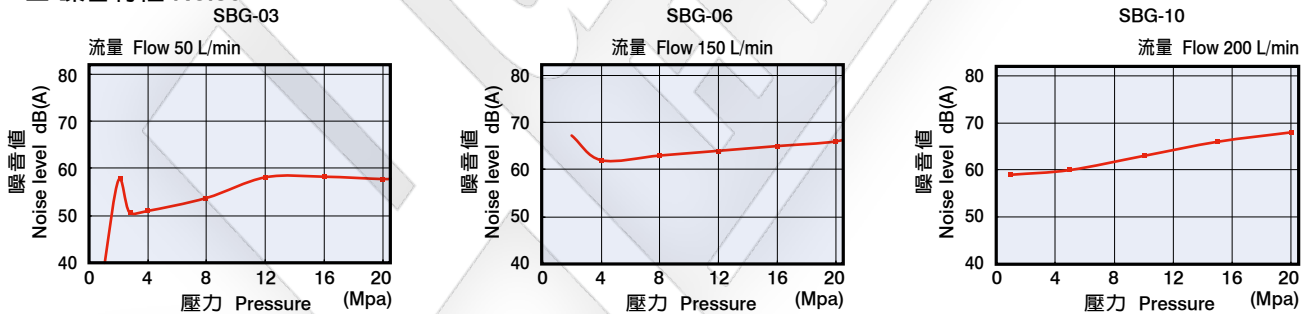

■ 流量-壓力特性曲線圖 The characteristic curve chart of Flow vs. Pressure.

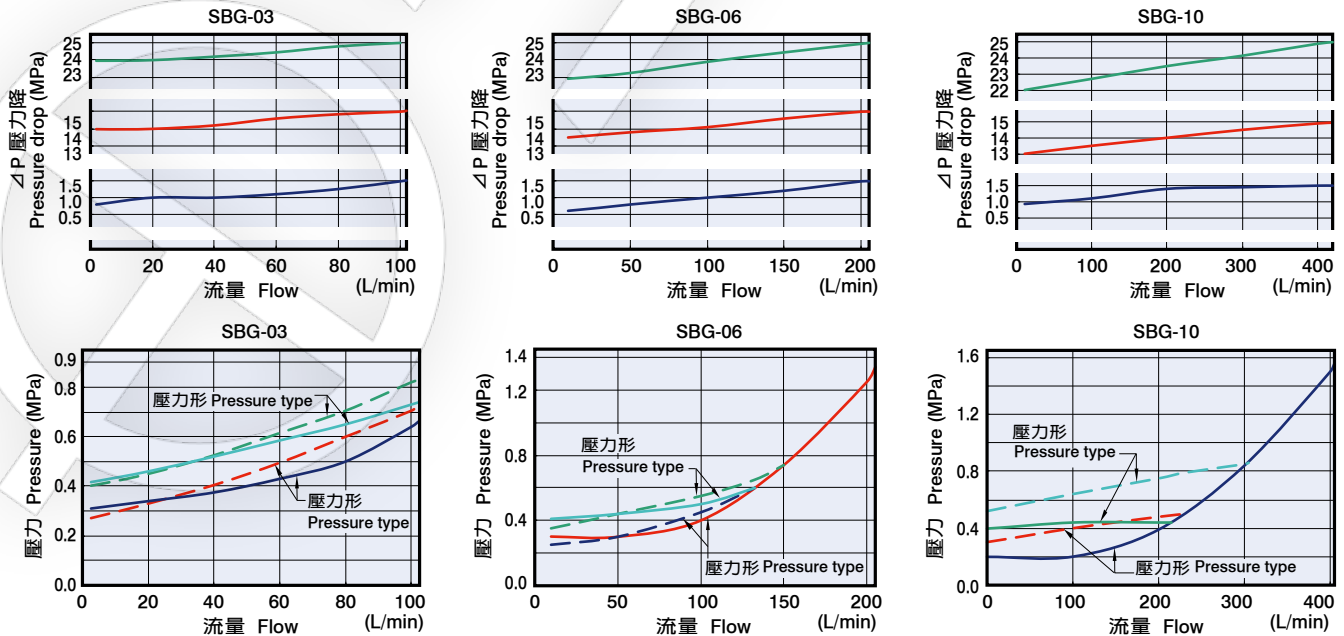

底版尺寸圖 Bottom plate dimensions

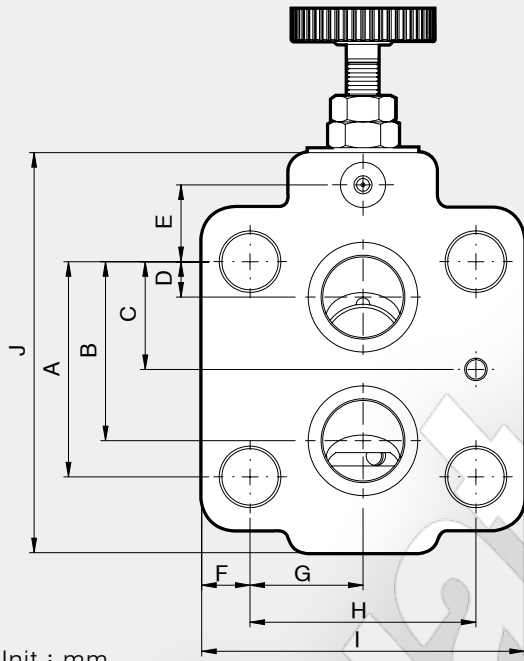

單位 Unit : mm

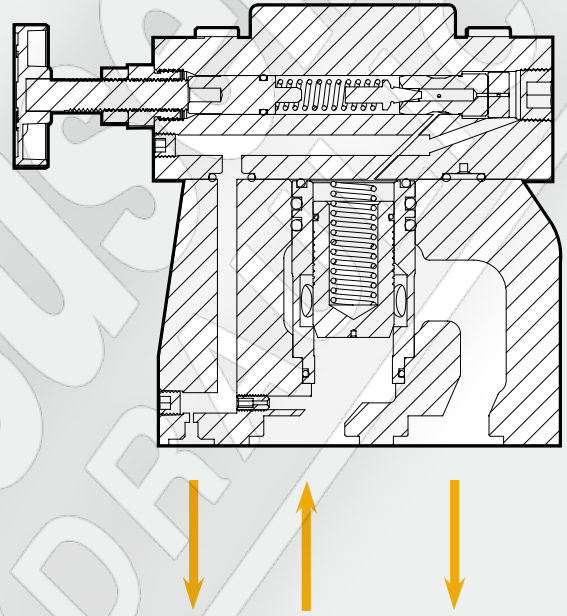

型號 Model	A	B	C	D	E	F	G	H	I	J		
SBG-03	53.8	47.4	22	22	0	12.1	26.9	53.8	78	107		
SBG-06	66.7	55.5	33.4	11	23.8	15	35	70	100	124		
SBG-10	88.9	76.2	44.5	12.7	31.8	22.2	41.3	82.6	127	155		

爆炸圖 How to order for a complete assembled valve

SBG-03.06.10

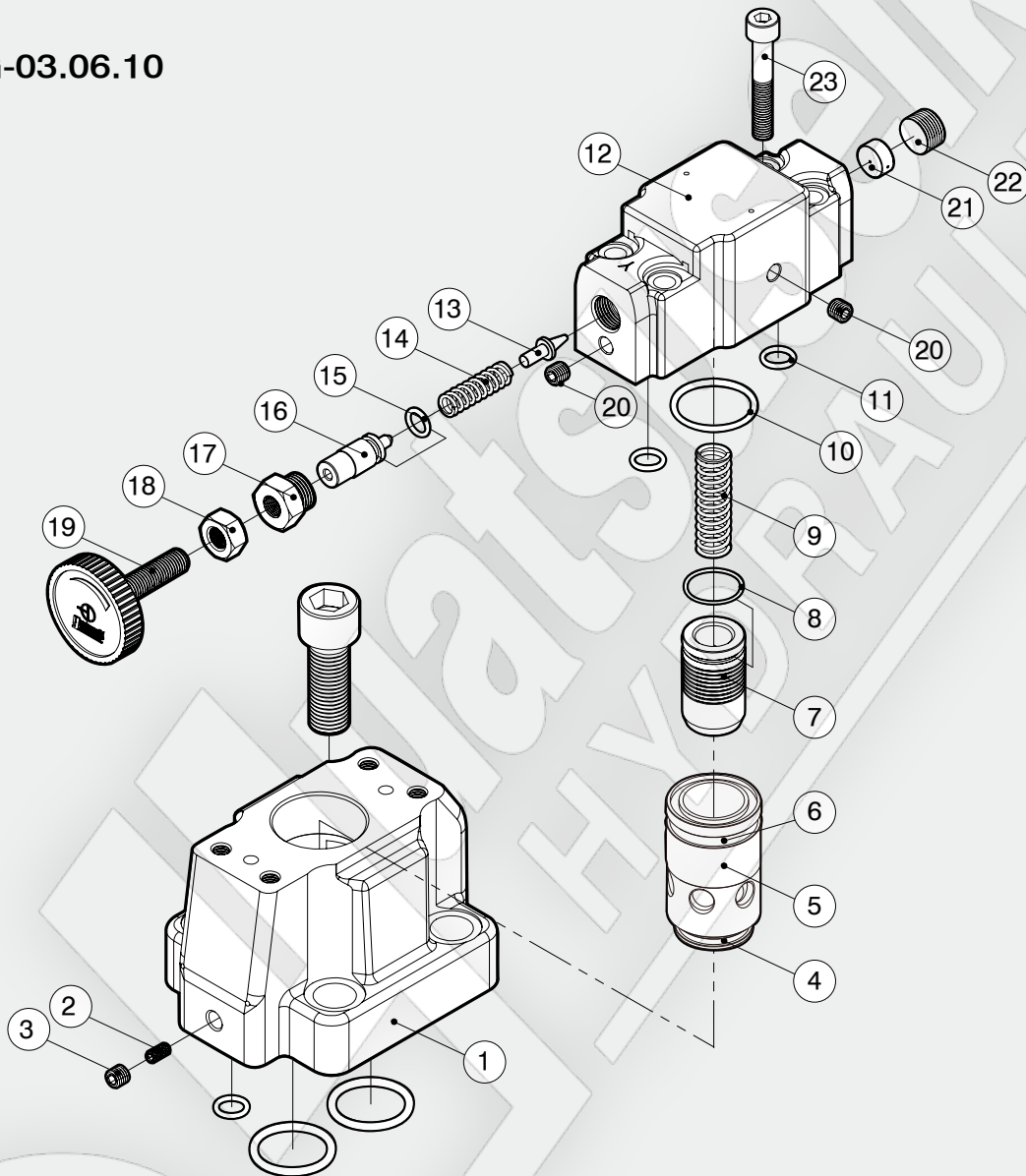

項次編號 No.	品名 Name of parts	數量 Q
1	本體 Body	1
2	M5 x 8L 通孔螺絲 Through hole screw	1
3	PT 1/16	1
4	SBG-03.06 2-024 x 1, 8-024 x 1	1
	SBG-10 JIS B 2401-1A-P42	1
5	槍子閥座 Check valve seat	1
6	SBG-03.06 2-028 x 1, 8-028 x 2	2
	SBG-10 JIS B 2401-1A-P44	1
7	槍子閥 Check valve	1
8	SBG-03.06 SM-32	1
	SBG-10 無 None	
9	彈簧 Spring	1
10	SBG-03.06 2-123	1
	SBG-10 JIS B 2401-1B-P38	1

項次編號 No.	品名 Name of parts	數量 Q
11	JIS B 2401-1A-P10A	2
12	閥蓋 Cover	1
13	針閥 Pilot poppet	1
14	彈簧 Spring	1
15	JIS B 2401-1A-P9	1
16	推桿 Push rod	1
17	把手螺母 Nut	1
18	六角螺母 Nut	1
19	壓力調整把手 Pressure adj. handle	1
20	PT 1/16	2
21	消音墊片 Washer for noise reduction	1
22	PT 3/8	1
23	M8 x 50L	4