

壓力控制閥 (引導動作型溢流閥) PRESSURE CONTROL VALVE (Pilot operated relief valves)

- HDRI 之產品採用引導動作型設計，具低噪音特性。提供油壓系統之穩壓功能。
- HDRI is designed with pilot, and low noise. Regulator function of the hydraulic system.



HDRI-03



HDRI-03-G

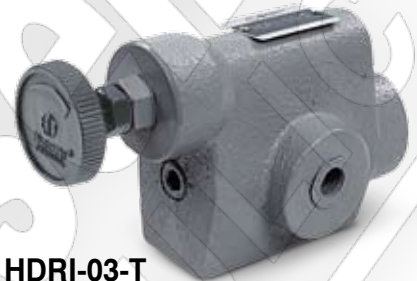

HDRI-03-T

型號意義 How to order :

HDRI - 03 - ※
1 2 3

1 系列號	Series
2 口徑代號	Valve size 06:3/4"
3 壓力調整範圍	Pressure adjusting range

產品規格 Specification :

名稱 Name	口徑 Valve Size	型號 Model	壓力調整範圍 Pressure Adj. Range (Kgf/cm ²)	最大流量 Max. Flow (ℓ/min)	重量 Weight (Kg)
引導動作型溢流閥 Pilot operated relief valves	3/8	HDRI-03	B: 7~70	100	3
		HDRI-03-G	C: 7~140		3.5
		HDRI-03-T	H: 7~210 2H: 7~210		3

附件 Attachment :

型號 Model	安裝螺絲 Mounting bolts		O 型環 O-Ring	
HDRI-03	M12 x 55L	4 支 piece	JIS B 2401-1B-P9 1 條 piece	JIS B 2401-1B-P18 2 條 piece
HDRI-03-G	M12 x 55L	4 支 piece	JIS B 2401-1B-P9 1 條 piece	JIS B 2401-1B-P18 2 條 piece

圖形符號 Graphic symbol :

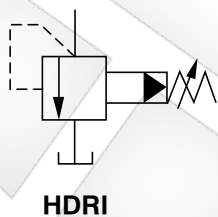

HDRI-03

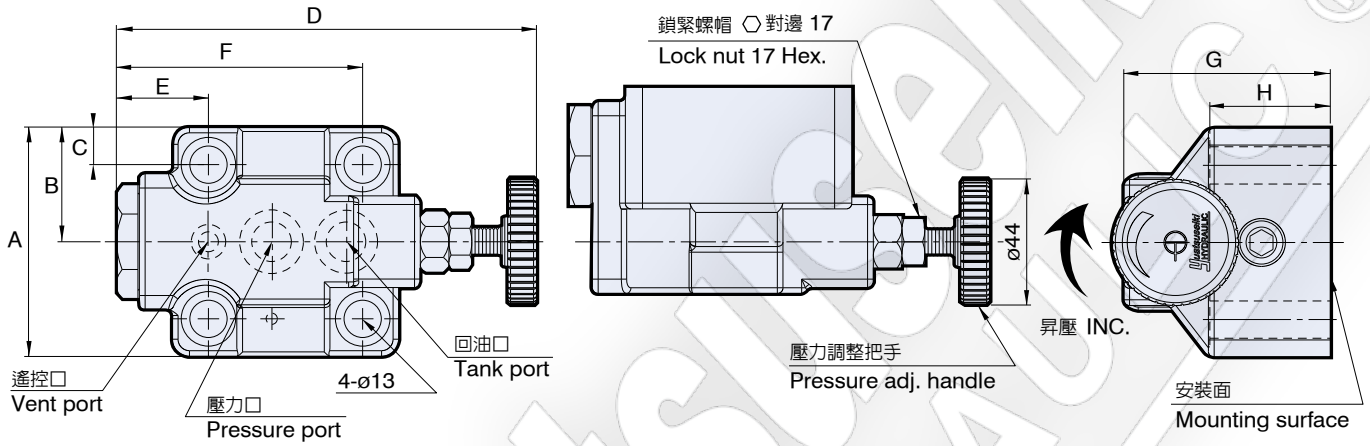

單位 Unit : mm

型號 Model	A	B	C	D	E	F	G	H				
HDRI-03	80	40	13	147	86	32	72	42				
HDRI-03-G	80	40	13	165	89	35	87	42				

HDRI-03T

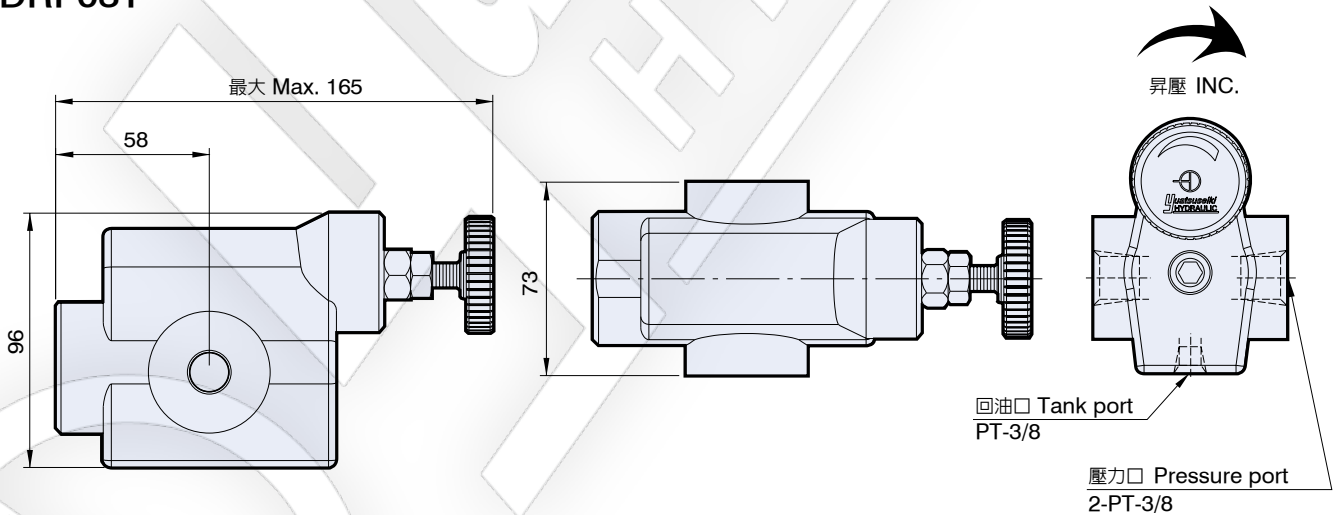

單位 Unit : mm

爆炸圖 How to order for a complete assembled valve

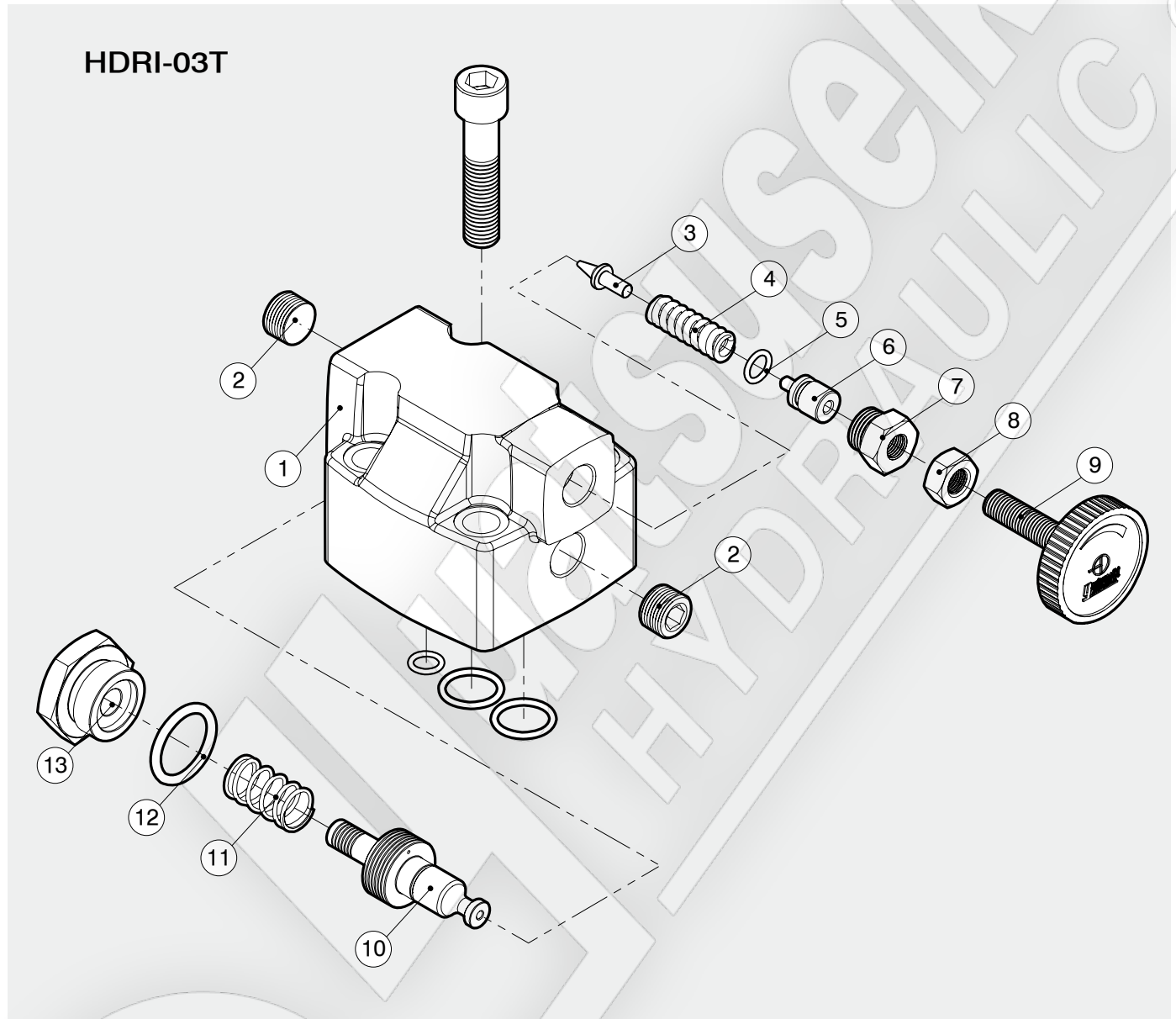

項次編號 No.	品名 Name of parts	數量 Q
1	本體 Body	1
2	PT 3/8	2
3	針閥 Pilot poppet	1
4	彈簧 Spring	1
5	JIS B 2401-1A-P9	1
6	推桿 Push rod	1
7	把手螺母 Nut	1

項次編號 No.	品名 Name of parts	數量 Q
8	六角螺母 Nut	1
9	壓力調整把手 Pressure adj. handle	1
10	心軸 Spool	1
11	彈簧 Spring	1
12	JIS B 2401-1A-P24	1
13	螺母 Nut	1