

# 方向控制閥 (液控單向閥)

## DIRECTIONAL CONTROL VALVE (Pilot controlled check valves)

- CPDG 系列液控單向閥，通常只允許單方向之油液流通，反方向則無法流通。
- 當液控壓力到達時，油液可反方向流通。
- Pilot controlled check valve CPDG series is only allowed one-way flow normally, not allow for reversion.
- When pressure reaches, flow can be reversion.



CPDG-03.06.10

方向控制閥 液控單向閥  
Directional Control Valve (Pilot controlled check valves)

### 型號意義 How to order :

**CP D - G - 03 - ※ - E**  
1 2 3 4 5 6

1 系列號	Series
2 無記號:單向閥 D:有泄壓閥的單向閥	No code: Pilot controlled check valve D: Decompression type pilot controlled check valve
3 板式連接	SUB-Plate mounting
4 口徑代號	Valve size 03:3/8", 06:3/4", 10:1-1/4"
5 開啓壓力	Cracking pressure Kgf/cm <sup>2</sup>
6 無記號:內部回油 / E:外部回油	No code: Internal drain / E: External drain

### 產品規格 Specification :

名稱 Name	口徑 Valve Size	型號 Model	開啓壓力 Max. Pressure (Kgf/cm <sup>2</sup> )	最大流量 Max. Flow (ℓ/min)	重量 Weight (Kg)
液控單向閥 Pilot Controlled Check valves	3/8	CPDG-03	5: 0.5Kg 50: 5Kg	50	5
	3/4	CPDG-06		125	6.5
	1-1/4	CPDG-10		315	12

### 附件 Attachment :

型號 Model	安裝螺絲 Mounting bolts	O 型環 O-Ring
CPDG-03	M10 x 70L 4 支 piece	JIS B 2401-1B-P9 2 條 piece JIS B 2401-1B-P20 2 條 piece
CPDG-06	M10 x 50L 4 支 piece	JIS B 2401-1B-P9 2 條 piece JIS B 2401-1B-P29 2 條 piece
CPDG-10	M10 x 85L 4 支 piece	JIS B 2401-1B-P9 2 條 piece JIS B 2401-1B-P38 2 條 piece

### 圖形符號 Graphic symbol :

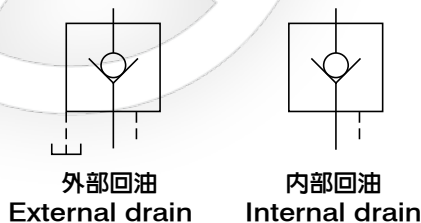

### CPDG-03.06

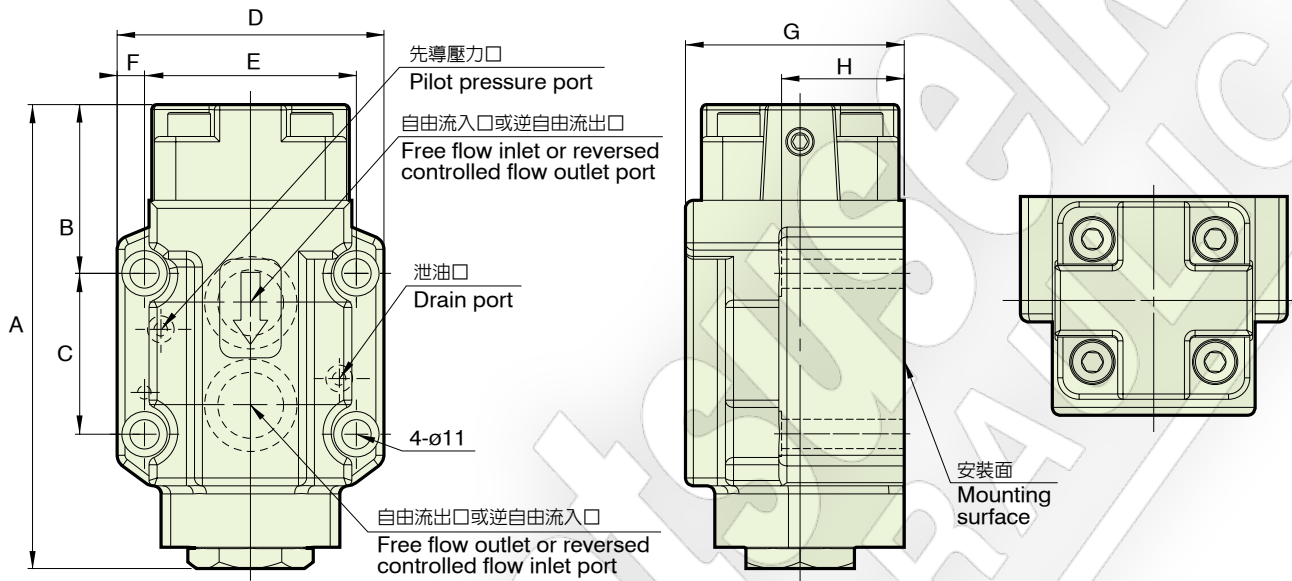

單位 Unit : mm

型號 Model	A	B	C	D	E	F	G	H				
CPDG-03	148	52.6	42.9	91	66.7	12.2	70	61				
CPDG-06	174	63.4	60.3	100	79.4	10.3	82	46				

### CPDG-10

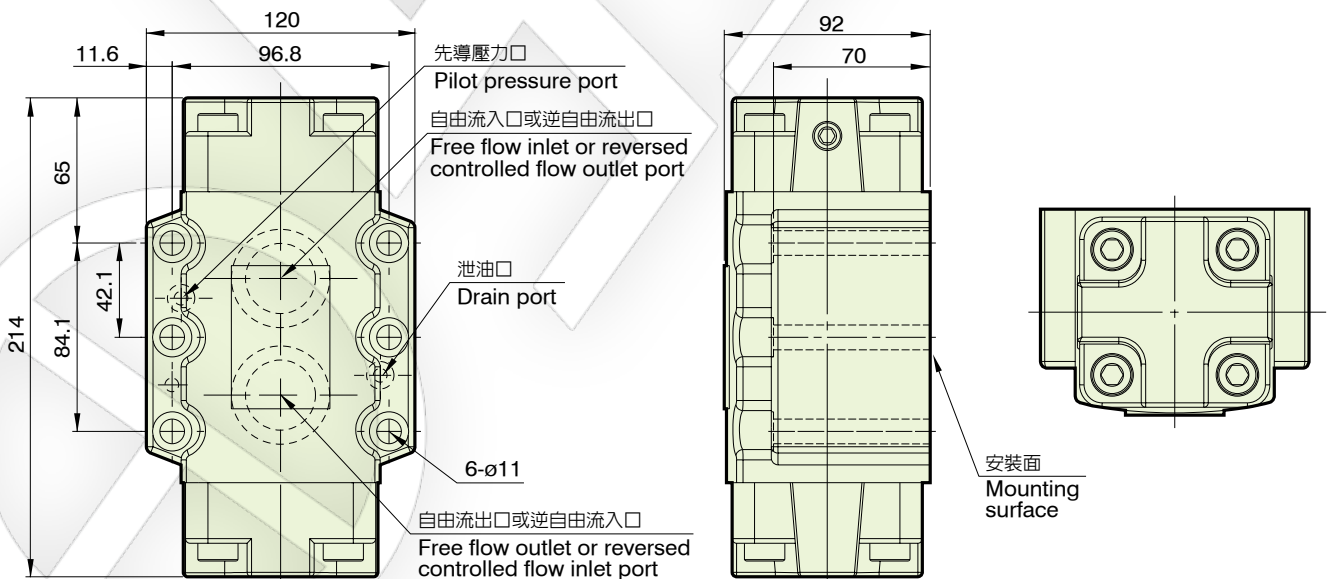

單位 Unit : mm

### 性能曲線圖 Performance curves

#### ■ 流量-壓力特性曲線圖

The characteristic curve chart of Flow vs. Pressure

使用油：黏度 Test fluid viscosity: 30mm<sup>2</sup>/s {cSt}

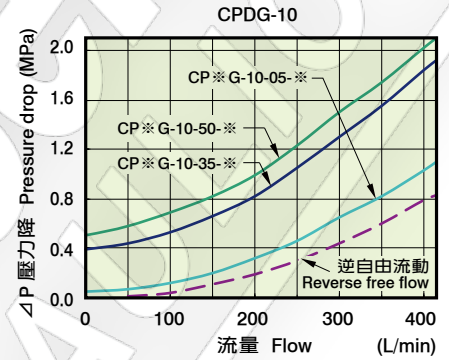
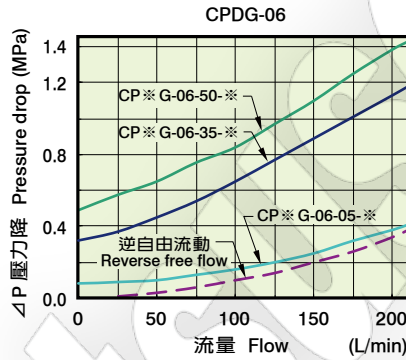
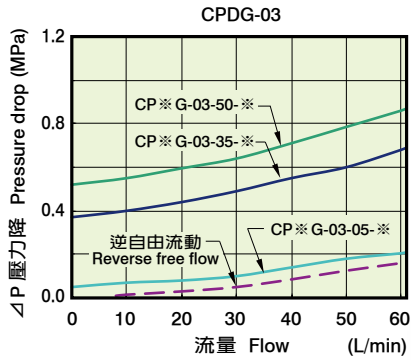

#### ■ 最低先導壓力特性

Minimum pilot pressure characteristics

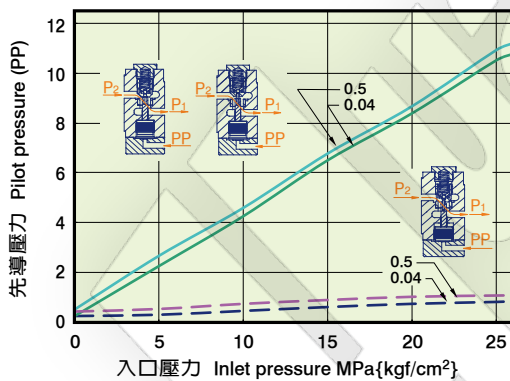

#### ■ 第一段全開壓力降特性

Character of dropping pressure for First Level

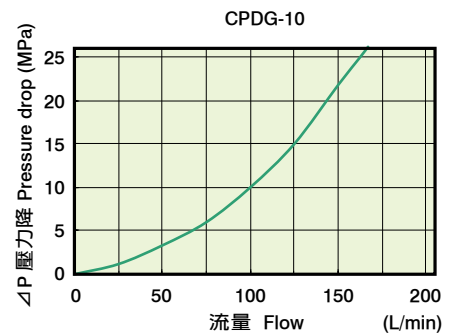
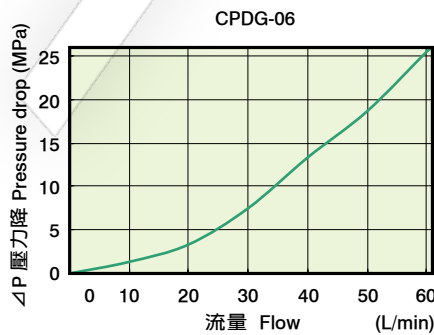
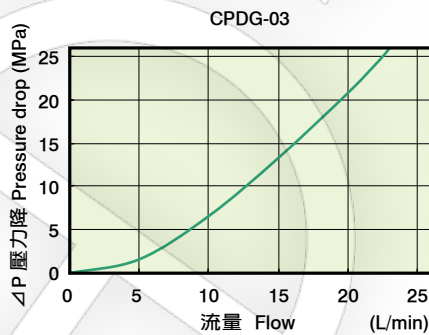

### 爆炸圖 How to order for a complete assembled valve

CPDG-03.06.10

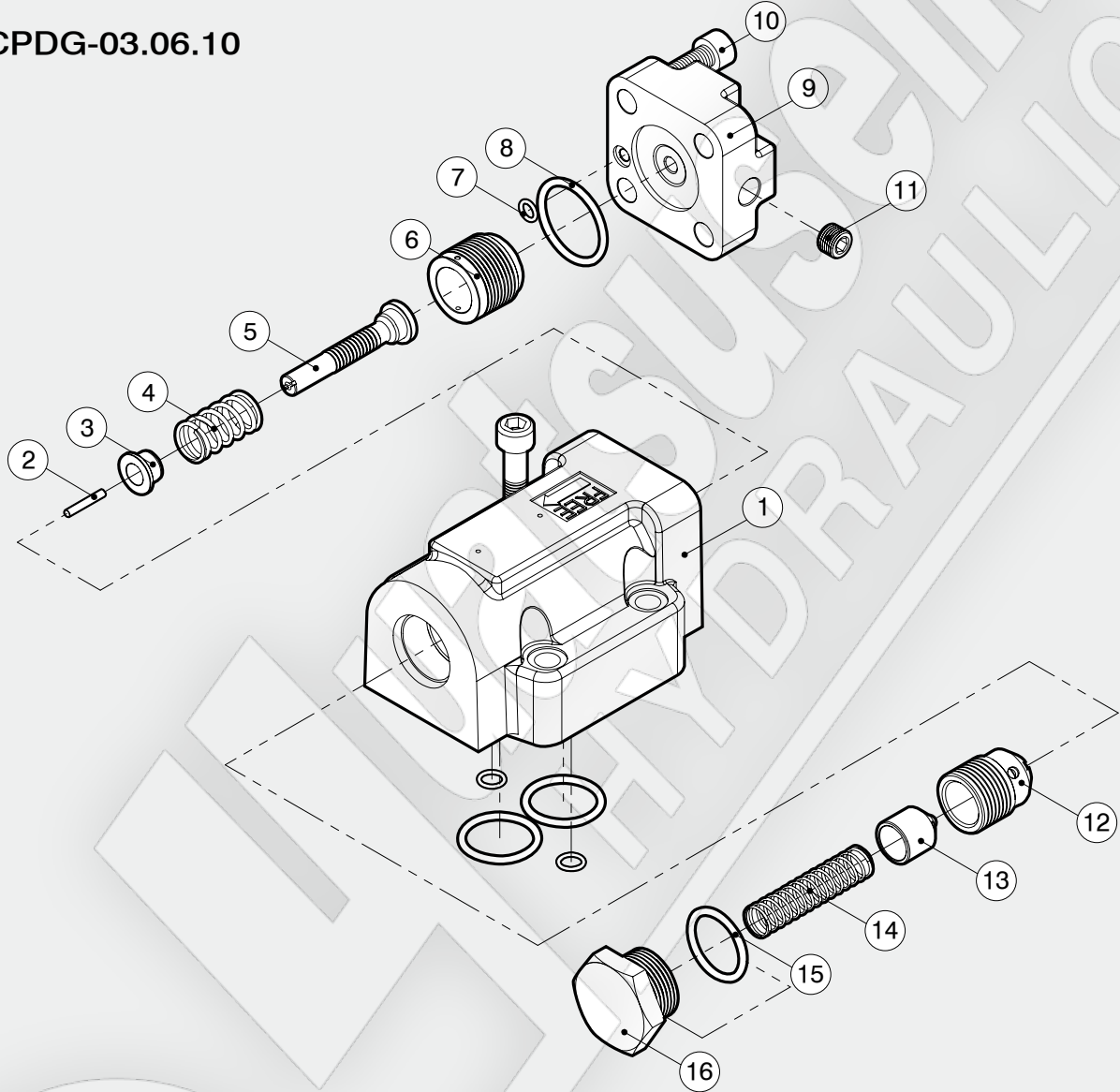

方向控制閥  
液控單向閥  
Directional Control Valve (Pilot controlled check valves)

項次編號 No.	品名 Name of parts	數量 Q
1	本體 Body	1
2	鋼棒 Just stick	1
3	墊片 Washer	1
4	彈簧 Spring	1
5	推桿 Push rod	1
6	活塞 Piston	1
7	CPDG-03 JIS B 2401-1B-P6	2
	CPDG-06 JIS B 2401-1B-P7	1
	CPDG-10 JIS B 2401-1B-P9	2
8	CPDG-03 JIS B 2401-1B-G25	2
	CPDG-06 JIS B 2401-1B-P34	1
	CPDG-10 JIS B 2401-1B-P44	2

項次編號 No.	品名 Name of parts	數量 Q
9	閥蓋 Cover	1
10	CPDG-03 M8 x 35L	8
	CPDG-06 M10 x 35L	4
	CPDG-10 M12 x 40L	8
11	PT 1/4	1
12	槍子閥 Check valve	1
13	球閥座 Check valve seat	1
14	彈簧 Spring	1
15	CPDG-06 JIS B 2401-1A-P28	1
16	螺母 Nut	1